

Workshop on Electricity and Magnetism

2002 Colorado science Convention

Presented by Dr. Willis's Seminar in Teaching Physics Class @ UNC
Class web site: <http://physics.unco.edu/sced441>

Kelly Johnson, Veronica McMullin, Brain Firooz, and Philip Harrison

The following are activities and investigations which can be used to develop concepts in electricity and magnetism.

NORTH AND SOUTH

Ever wonder why a magnet attracts some things but not others? Or why some metals are magnetic? Magnetism is one of the topics you will be exploring today.

Magnets work because the atoms that make up the material are all lined up in a particular way. It is believed that atoms have a north and south pole, like the earth. In a magnet, when the atoms are lined up, the poles are also lined up. This creates strong attractions at the ends of the magnet.

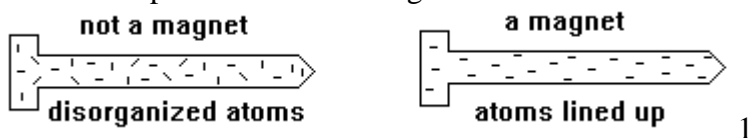

A. THE MAGIC OF MAGNETS?

What kinds of materials are attracted by a magnet? You probably think of metals, but all metals? What about metals that are chemically combined with other materials--like metal salts. An example is sodium chloride, NaCl, commonly known as table salt.

Get a magnet, some iron filings, a piece of copper wire, a piece of aluminum foil, and some table salt. Put the table salt and the iron filings in a ziploc baggie.

Will the magnet attract the aluminum foil? How about the copper wire?

Hold the magnet next to the baggie of salt and filings. Describe what happens.

Why do you think the magnet attracts the iron filings but not the other materials?

Can you use a magnet to make another magnet? Think for a minute--have you ever noticed that sometimes scissors will attract pins or nails will attract other nails?

Get a large nail and a couple of small nails. Try to pick up the smaller nails with the larger nail. What happens?

Now rub the nail against the magnet 10-15 times. Start at the head and rub the magnet from the head to the tip. It is best to rub the nail in one direction. Try to pick up the small nail. What happens?

Why do you think the large nail picked up the small nail?

You are right. Rubbing the nail with the magnet caused some of the atoms in the large nail to line up, so the nail now acts like a magnet. But is this a permanent change?

Hit the large nail with a hammer a couple of times and try to pick up the small nail. What happens?

Chances are, the large nail either didn't pick up the small nail or it had trouble picking up the small nail. When you pounded on the large nail, some of the lined-up atoms moved around and got all jumbled up. So the nail "lost" some of its magnetism. Some of the atoms are still lined up, but not enough to attract another nail.

Get a second magnet. See if the magnets always attract each other, no matter which ends you put together. What happens when you do this?

What you have found is that your magnets have a north and a south pole, and that the poles attract when north meets south. When north meets north or south meets south, the poles repel each other.

B. HOW DO I KNOW WHERE I'M GOING?

Compasses are useful for helping us navigate on a hike. They also help pilots fly planes. Your magnet acts as a compass--all you need is some string!

Get a piece of thread and tie it around the center of the magnet. Hold the other end of the string and let the magnet hang down.

What happens when you try to twist the magnet so the ends point towards different directions?

You probably noticed that one end of the magnet always moved so that it points in the same direction. The north seeking pole of a magnet tries to point towards the earth's north pole. The magnet's south seeking pole points towards the earth's south pole.

A compass works in much the same way. In a compass, the magnet sits on a pin so it can move easily.

You can make a compass out of a sewing needle (or nail or paper clip) and a styrofoam raft cut from the bottom of a styrofoam cup. Get a sewing needle, a styrofoam raft, a magnet, a compass and a container of water.

Magnetize the sewing needle by rubbing the magnet along the needle (do this in one direction--like the nail you did earlier).

Lay the needle into the top of the styrofoam. Now float the styrofoam in the water so that the needle is parallel to the water.

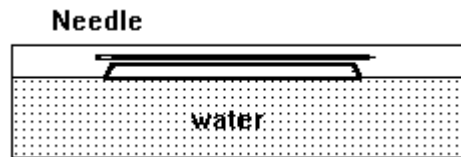

2

Compare the position of the needle in your cork compass to the needle of the "real" compass. What happens to the needle on each one when you move them?

C. HOW STRONG IS YOUR MAGNET?

Can magnets attract things they are not touching? How far away can a magnet and an object get before the magnet can't pull it any more?

Get a magnet, some nails, and a ruler. Put the nail on the table and place the ruler next to it. See how close you can slide the magnet towards the nail before they are attracted. How close can you get?

See if your magnet will attract a nail through different materials. Try paper, a book, glass, plastic, wood, whatever you can find. Describe your discoveries in the space below.

D. WHY DO WE NEED MAGNETISM?

Magnets are pretty useful for a lot of things other than compasses and holding papers to your refrigerator. Running electricity through some metals makes an electromagnet, and these can be very strong. They can be used to lift heavy machinery. Magnets also allow us to listen to a cassette tape!

Look inside of the tape recorder. You will see a little silver box-shaped piece. Push "play" and this silver piece (among others) will move out.

When a tape is playing, the tape part moves across this silver piece. The silver piece is an electromagnet. A cassette tape has music recorded on it as magnetic patterns--tiny particles on the tape get arranged in certain patterns when the tape is made. When the tape is played, the electromagnet responds to the patterns on the tape and sends electrical signals which correspond to the sounds you hear.

INVESTIGATING STATIC ELECTRICITY

1. To start this investigation you will first need to stick a flexible straw in each of two small pieces of modeling clay to form inverted “L”s. These will serve as holders for the test strips that you will make next (see diagram below).
2. To prepare a pair of test strips, first obtain a strip of “Scotch Brand: Magic Mending Tape” about 12 to 13 cm long. Fold over about .5 cm of tape at one end to form a non-sticky tab. Stick this strip of tape to the tabletop and use a pencil to mark an “A” on the non-sticky tab. Next, prepare a second strip of tape in exactly the same manner. Stick the second strip of tape directly on top of the first piece of tape and mark a “B” on its non-sticky tab.
3. Stick the strip of tape marked “A” on one of the flexible straw holders you mad in step 1 and the strip marked “B” on the other holder.

4. Prepare a second set of test strips from the table together. Bring the strip marked “A” near the hanging strip marked “A” near each of the strips marked “B” near each of

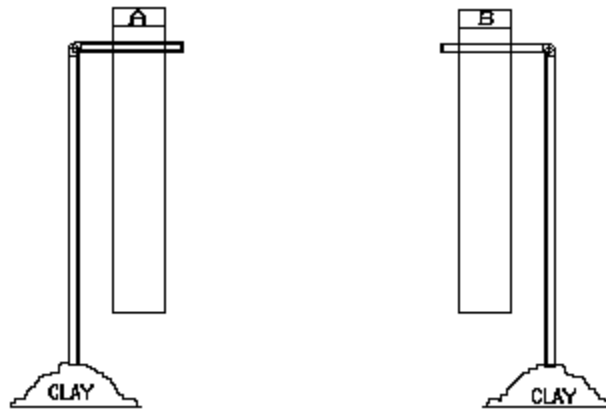

Remove both strips of tape from the tabletop. Bring the strip marked “A” near the hanging strip marked “A” near each of the strips marked “B” near each of the following table.

Hanging Strip “A”			
Hanging Strip “B”			

5. If an object has an electrical charge it will have to behave as either “A” or “B” in the table above. Write a general statement of this behavior.

6. If an object was attracted to both strips “A” and “B” could you determine whether or not it has an electrical charge?

7. At your table you will find a number of objects. Try rubbing each of the objects with a cloth or paper towel. First bring the object near hanging strip “A” then near hanging strip “B”. **THERE ARE SPACES PROVIDED FOR YOU TO TRY SOME OBJECTS OF YOUR OWN.** Record your observations in the table below. If your charged strips seem to lose charge, you can recharge them by repeating step #3 above.

	“A” strip“	B” strip
plastic plumbing pipe:		
Plexiglas:		
plastic silverware:		
wood:		
glass test tube:		
plastic test tube:		
rubber balloon:		
overhead transparency:		
metal nail:		
name tag holder:		
Styrofoam:		

8. Which of the above items did NOT give a definite indication that it had been electrically charged after it was rubbed with cloth? **EXPLAIN**

9. The phenomenon you have just observed was first recorded by Thales of Miletus nearly 2500 years ago in ancient Greece. He observed that pieces of amber when rubbed with fur would attract feathers and dried leaves. During the middle ages, it was noted that a glass rubbed with silk or cotton would behave similarly. It remained just an interesting phenomenon until about 1600 when Sir William Gilbert made the first systematic study of the phenomenon. He called the phenomenon 'electricity' after 'electron', the Greek word for amber. In 1747, Benjamin Franklin became America's

first internationally known scientist after publishing his studies on electricity. Besides flying his kite in a thunderstorm, and inventing the lightning rod, Franklin was the first to name the two types of electricity plus and minus. After it had been rubbed with cloth, Franklin named the kind of electricity found on glass 'plus' or 'positive' electricity. Even though some of Franklin's original ideas of electricity have now been replaced, people have continued calling the two types of electrical charge 'plus' and 'minus' (positive and negative). Use this information to determine the type of electrical charge found on the objects in part 3. Be ready to defend your choices.

Charge

plastic plumbing pipe:	
Plexiglas:	
plastic silverware:	
wood:	
glass test tube:	
plastic test tube:	
rubber balloon:	
overhead transparency:	
metal nail:	
name tag holder:	
Styrofoam:	

SUMMARY AND APPLICATIONS:

10. Does an object have to have an electrical charge to be attracted to an electrical charge? Give an example.

11. (a) Below, list the procedure you would use to determine the charge on an unknown rubbed rod based on the information you have gained thus far.

(b) Set up your apparatus as described in your procedure and ask the instructor test a rod of unknown charge. Describe the results below and indicate the charge of the rod.

12. The question : Is a thin stream of water charged? If so, what is its charge? Plan a procedure you and your students could perform to find out. Now perform the necessary investigation to answer the question. Write your procedure, data and conclusion below.

TRIBOELECTRIC SERIES

Courtney W. Willis, Physics Department, University of Northern Colorado, Greeley, CO 80639

When two materials on this list are rubbed together, the material higher on the list will become positively charged while the material lower on the list will become negatively charged.

I	P	+++	Air
n	o		Acetate (for overhead projectors)
c	s		Human hands
r	i		Acrylic plastic (Plexiglas)
e	t		Asbestos
a	i		Rabbit fur
s	v		Glass
i	e		Mica
n		++	Human hair
g			Nylon
l			Wool
y			Cat Fur
			Lead
		+	Silk
			Aluminum
			Paper
	Neutral		Cotton
			Steel
			Wood
			Amber
		-	Sealing wax
			Hard rubber
			Nickel, copper
I	N		Gold, platinum
n	e		Sulfur
c	g		Acetate, Rayon
r	i		Polyester
e	t	--	Celluloid
a	i		Orlon
s	v		Saran
i	e		Polyurethane
n			Polyethylene
g			Polypropylene
l			PVC (vinyl)
y			Silicon
		---	Teflon

FALLING MAGNETS - ELECTROMAGNETIC INDUCTION

(© 1998, Courtney W. Willis, Physics Department, University of Northern Colorado, Greeley, CO 80639)

Moving electric charge (electric current) produces magnetic fields and moving magnets produce electric fields. This dynamic relationship between Electricity and Magnetism can be used to demonstrate some very interesting phenomena.

If a falling magnet is surrounded by metal, the electric field produced by the moving magnet will induce an electric current in the metal. The magnetic field produced by the induced electric current opposes the fall of the magnet according to Lenz's law. If the magnet is strong enough, the induced electric current can produce a magnetic field strong enough to appreciably slow the fall of the magnet. This is also an interesting example of the conservation of energy. As the falling magnet loses potential energy it induces an electric current which in turn is converted to heat. An interesting example of this can be seen as the "fail safe" brake on free fall rides in amusement parks.

This can be demonstrated two ways:

1. A neodymium button magnet about 1 cm in diameter can be rolled down a piece of Aluminum channel. The motion of the magnetic can be compared to the motion of a similar non-magnetic button. The non-magnetic button will accelerate unimpeded down the channel while the magnetic button will roll slowly down the channel with a constant velocity.
2. A neodymium button magnetic can also be dropped down a vertical piece of copper or aluminum tubing about 1/2 inch in diameter. A similar non-magnetic button will accelerated down the tube with an acceleration nearly that of "g". The magnetic button will move through the tube very slowly taking 5 or 10 seconds to fall a meter. If the button magnetic is dropped through a piece of PVC tubing it will fall with the same acceleration as the non-magnetic button. The falling buttons can be heard as they bump against the walls during the fall.

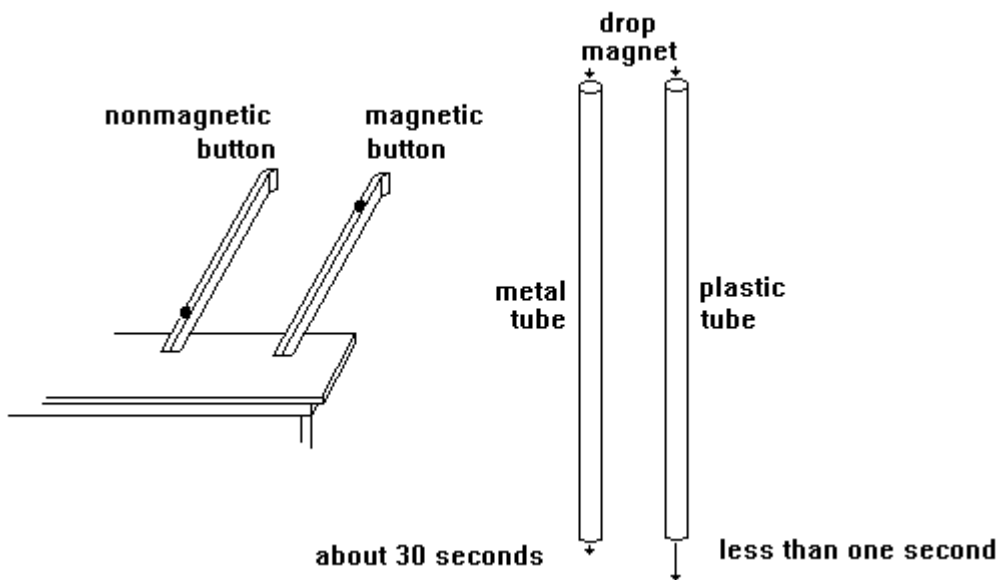

FLASHING - ELECTROMAGNETIC INDUCTION

(© 1998, Courtney W. Willis, Physics Department, University of Northern Colorado, Greeley, CO, 80639)

The idea that moving electric current produces a perpendicular surrounding magnetic field is relatively easy to demonstrate with a compass needle and a long straight wire. The concept of a changing magnetic field can produce an electric current is a bit harder to demonstrate to a large group. One of the easiest and most attention getting demonstrations is to use a conventional flash bulb.

If a conventional flash bulb (it can be a single bulb or flash cube, it can not be a Magic X cube) is attached by wires about 1 meter long to a coil of wire (20 to 50 turns, 10 cm. in diameter), when the coil is quickly moved through a strong magnetic field the resulting current will set off the flash bulb. This is usually quite convincing to students since most students understand that it take electric current to excite a flash bulb.

The magnet that produces the field must be quite strong. It can be a large horse shoe magnetic or two of the neodymium super magnets (about 2 cm. cubed) held two to three centimeters apart.

Flash bulbs and cubes are getting harder to find but some times show up in reasonable quantities at reasonable prices at Goodwill Stores or garage sales.

The demonstration works because as the coil of wire is moved the magnetic flux passing inside the coil changes. This changing magnetic flux produces a current in the wire which in turn flashes the bulb.

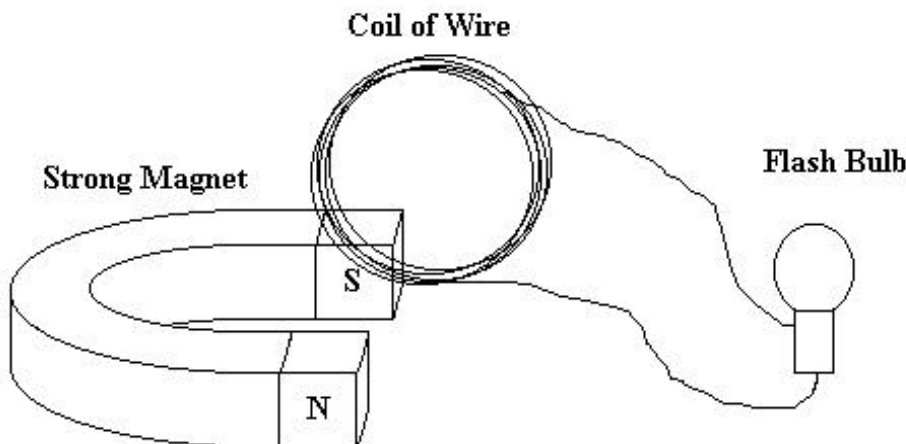

BATTERIES AND BULBS

In this activity you will extend your knowledge of electricity through an activity on electricity in motion (electrodynamics). The procedure follows.

1. You will first be given a flashlight battery which you are to investigate and write answers to the following questions regarding the battery.

- (a) Voltage is an electrical term which is related to electrical energy but it can give an indication of the amount of “push” available to charges. It is more rigorously referred to as the electrical potential or the electrical potential difference. Its SI unit is the Volt. What is the voltage of your battery?

- (b) Chemical reactions are occurring within the battery and as a result of this chemistry, the battery has a negative and a positive terminal. Identify these two terminals on your battery.

- (c) What has to happen for the negative terminal to become negatively charge? the positive terminal to become positively charged?

- (d) Apply the above information to give a scientifically sound reason how a battery goes dead?

- (e) If you were to connect a conducting wire between the two terminals, why would you expect a flow of electrons to pass through the wire?

This flow of electrons is non-rigorously defined as current. Electrical current is operationally defined as the number of charges passing a given point per unit time. The SI unit of current is the Ampere, most often referred to as “amp.” Although most everyone tends to want to concentrate on voltage it is the effects of **CURRENT** that people can most easily observe. **CURRENT** is what makes things happen.

2. You will now be given two insulated wires (called leads) and a flashlight bulb (you can unscrew one from the circuit board if you do not have a free bulb).

CAUTION: Do not connect the two terminals using only a conducting wire. This is called a short circuit and it can cause excessive heating and produce a dead battery in short order.

(a) Problem: Using the two leads (the two leads cannot be connected together), light the free bulb with the battery. Show in a sketch below the electrical circuit that accomplished the task.

(b) Study the bulb and draw a sketch of it below, showing the path of the electrons as they pass through the bulb when it is lit. (*i.e. where can the current enter and leave the bulb?*)

(c) Question: Can you light the bulb by using only one lead? Show how you accomplished this below.

3. In order to establish a qualitative measurement in future work, you will first connect one bulb across single battery, then across two batteries, three batteries and finally all four batteries. The batteries in the case are connected in series (plus to minus, plus to minus, etc.) and the voltages are additive. From this investigation, fill in the table on the following page.

No. of Batteries	Effect on Brightness	Effect on Current

Since voltage is related to "push", to increasing the current it is necessary to _____ the voltage.

Thus, the brightness of the bulb indicates both the the amount of _____ flowing through and the _____ across the bulb.

4. Using all four batteries in the battery case and the necessary leads, make the following connections.

- (a) First, two bulbs connected across the batteries such that **all the electrons (current) flow through each bulb.**
- (b) Second, three bulbs connected across the batteries such that **all the electrons (current) flow through each bulb.**

What happened to the brightness of the bulbs as you added more bulbs to your circuit?

What happened to the total current as you added more bulbs to this circuit?

Unscrew one bulb and note what happens.

These bulbs are said to be connected in series, i.e., one after the other, with the total current passing through each bulb. Can you think of any common circuit which is wired in series?

5. Using all four batteries in the battery case and the necessary leads, make the following connections.
- (a) First, two bulbs connected across the batteries such that **the total electrons (current) are divided between the two bulbs.**
 - (b) Second, three bulbs connected across the batteries such that **the total electrons are divided among the three bulbs.**

What happened to the brightness of the bulbs as you added more bulbs to your circuit?

How does the current through each bulb compare in this type of circuit? How does it compare to the total current coming out of the battery?

These bulbs are said to be connected in parallel. The total current is divided among each of the bulbs. Question: Is a household wired in series or in parallel? Use the information you have gained in Nos. 4 and 5 above to give two pieces of evidence for your choice of answer.

6. Problem: Shown below is a schematic of a circuit which involves three bulbs and four batteries. Wire this circuit using your bulb board and four batteries in series.

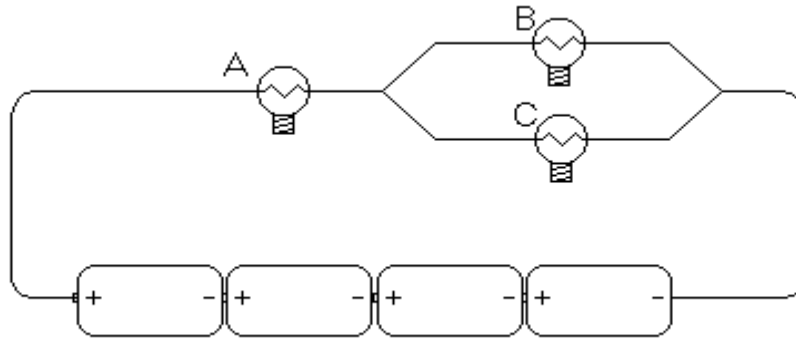

(a) After you have finished wiring the circuit, how could you readily tell whether it is correctly wired?

(b) Compare the currents in the A, B, and C bulbs and give an explanation for the degrees of brightness, based on the information you gained from Nos. 4 & 5 above.

7. Electricity travels through many materials. These materials are called conductors. Electricity does not travel as well through other materials. These are called insulators.

(a) How could you use a battery, wires, and a bulb as a tester for conductors and insulators in an elementary classroom? Draw a diagram of your tester.

(b) If you were given a wire, a strip of paper, a key, a paperclip, a twig, a penny, a piece of yarn, a pencil with both ends sharpened, a plastic button, some steel wool, and a piece of aluminum foil, how would you determine which were insulators and which were conductors of electricity? Give your own predictions for the above material (are they insulators or conductors?).

Workshop on Electricity and Magnetism
2002 Colorado science Convention

Web based resources for classroom and lab instruction in Science and Physics

Brought to you by Dr. Willis's Seminar in Teaching Physics Class @ UNC

Class web site: <http://physics.unco.edu/sced441>

Kelly Johnson, Veronica McMullin, Brain Firooz, and Philip Harrison

Graphics and Layout by Computer Assistance & Instruction--CAI (jnoa4@aol.com)

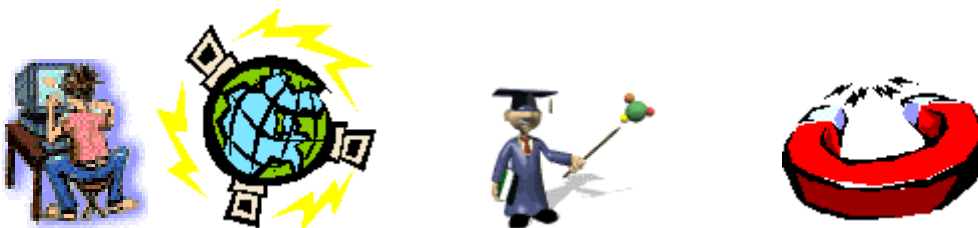

To visualize various concepts in math and physics

<http://falstad.com/mathphysics.html>

Pre-lab Exercise for Ohm's Law

http://webphysics.davidson.edu/physlet_resources/bu_prelabs/index.html

The Hands-On Technology Program

<http://www.galaxy.net/~k12/index.shtml>

Teacher Electricity Tools

<http://nsc10.nscdiscovery.org/TeacherResources/SearchItems/ThemeLookup.cfm?ThemeID=3&Start=0>

HyperPhysics

<http://hyperphysics.phy-astr.gsu.edu/hphys.html>

Electricity and Magnetism

<http://edtech.kennesaw.edu/web/electric.html>

Physics Lessons

<http://www.sciencejoywagon.com/physicszone/lesson/default.htm>

How Stuff Works

<http://www.howstuffworks.com/>

Magnetism and Electricity Science Links on the World Wide Web

<http://www.cssd11.k12.co.us/science/4magnet/links.htm>

Teaching Physics

http://webphysics.davidson.edu/physlet_resources/

Physlets, Physics Applets, are small flexible Java applets designed for science education. You do not need to become a Java expert in order to use Physlets.

<http://webphysics.davidson.edu/Applets/Applets.html>

Electricity and Magnetism!

<http://ippex.pppl.gov/interactive/electricity/>

Misc. Sites

<http://scitec.uwichill.edu.bb/cmp/online/P10D/p10D.htm>

<http://www.thinkquest.org/library/>

<http://whs.dist214.k12.il.us/www/academics/ms/s/physics/physicslinks.html>

Tech. Notes: via WEB

Depending on you computer and software (particularly the Browser) you will probably need to install various browser plugins or software such as java, shockwave etc.

The "Shockwave" Plug-in is required to use this module. You can get the Plug-in from the Macromedia Web site.

This archive contains JavaScript and Java Applets that may not run on all browsers. Please make sure you have a Java 1.1 capable browser. All exercises have been tested on Netscape Communicator version 4.7, Netscape Navigator 4.08, and Internet Explorer version 5.0 for Windows.

Windows users: Version 4.08 of Netscape Navigator is available on this CD in a subdirectory named Netscape. Netscape Navigator 4.08 is a smaller version of the full-featured browser package Netscape Communicator version 4.7.

Mac users: Currently, Physlet Problems **will not run** on a Macintosh Power PC. Mac browsers do not support both Java 1.1 and Java to JavaScript communication. Hopefully, this will change when version 5.0 browsers are released in 2000.

Errata: View the [errata page](#) to for a list of post-production corrections. Please report problems not listed on this page to the authors: wochristian@davidson.edu and mabelloni@davidson.edu